



The complete
consumer unit

 elucian





The complete consumer unit

Elucian by Click® brings to market a comprehensive Consumer Unit and Circuit Protection range.

Following months of extensive research and consultation with contractors and installers, we developed a range of products that best suits their requirements and that are compliant with all the latest regulations.

Designed with the installer in mind, Elucian is an extensive range of metal consumer units that will cover a broad range of installations and offers a number of features and benefits that will enhance the products' convenience, flexibility and safety properties.

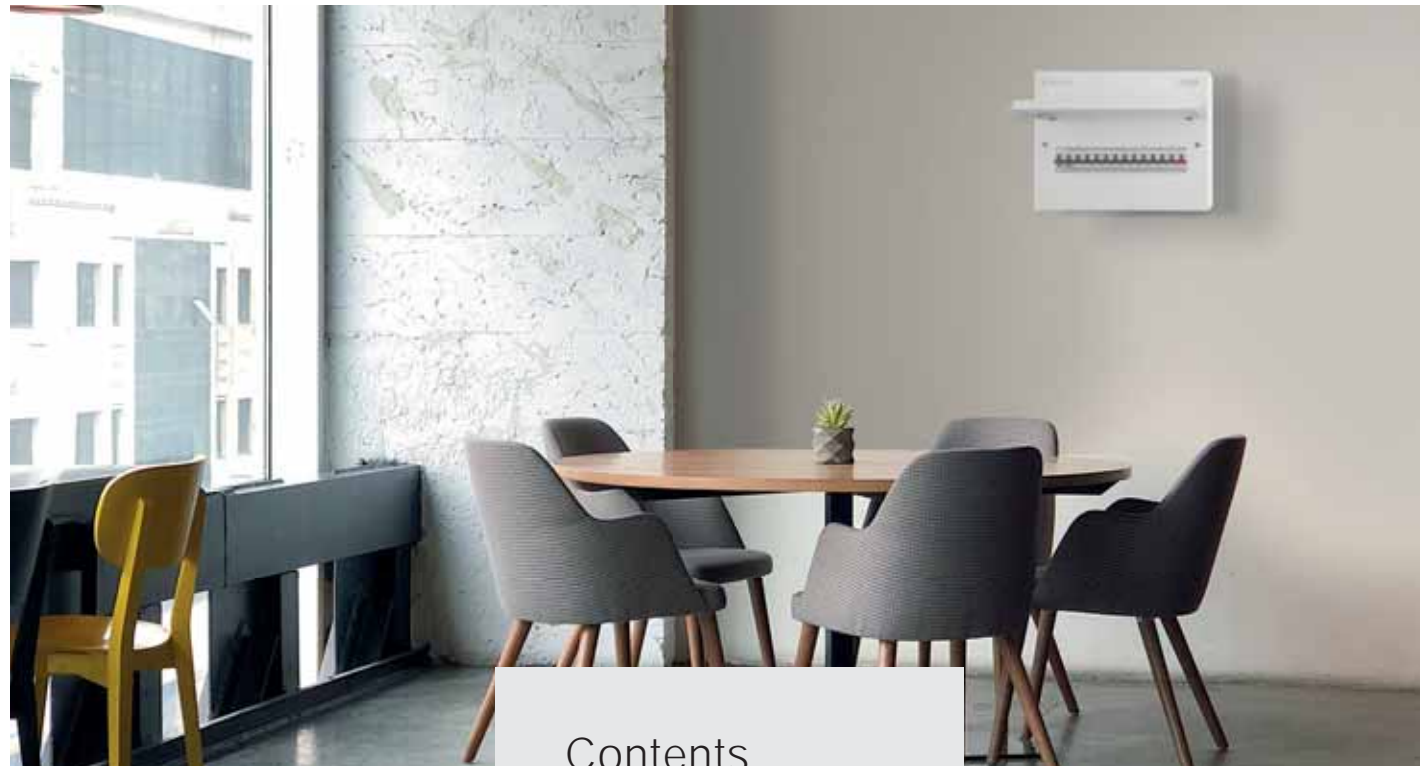

Contents

Regulations	B5
Consumer Units	B13
Protective Devices	B26
Technical Information	B43
Installation Information	B69





Keeping Up with Regulations...

The Elucian consumer units range has been designed to ensure compliance with BS 7671. Our engineers have considered how installers need to comply with the UK wiring regulation when installing consumer units in properties across the UK. The Elucian range has comprehensive options for every installation. These consist of Main Switch units, Split Load units and our Combination units.

Overload Protection (536.4.3.2) & (536.4.202)

Overload protection must be considered when RCCBs have the ability to become overloaded due to the total amount of current being taken by the final circuits being offered protection.

The designer and installer must therefore select the correct rated device from the options we have made available; 63Amp, 80Amp or 100Amp. To make this process easier we have installed 80Amp devices as standard.

Overcurrent Protection (Section 443) & (Section 553)

SPDs offer very effective protection against overvoltage. Section 443 covers the requirements for consideration when selecting SPDs in the electrical system. Section 533 confirms what types are required and where they must be installed within the electrical system.

We have designed our SPD consumer unit to incorporate a type 2 device. These devices offer protection from man-made overvoltages or lightning strikes within the vicinity of the installation.

Having SPDs installed adjacent to the main switch allows for compliance with the maximum cable length from the SPD to Earth.

Types of RCD (531.3.3)

Many different types of RCD exist. BS 7671 recognises types AC, A, F and B. Currently AC RCDs are recognised as acceptable for general purpose. However, if the installation has any DC components or frequency alterations due to connected loads one of the other types must be selected.

As most installations in the UK now have some DC components, it would be prudent to select a type A RCD that has the ability to work with DC fault current. We have produced type A RCDs only as they comply with the requirements of the AC type, and include added benefits of the DC threshold.

Division of Installation (Section 314)

This regulation set requires the designer and installer to ensure the installation is divided up as necessary to:

- (i) Avoid danger and minimise inconvenience in the event of a fault.
- (ii) Facilitate safe inspection, testing and maintenance.
- (iii) Take account of hazards that may arise from the failure of a single circuit such as a lighting circuit.
- (iv) Reduce the possibility of unwanted tripping of RCDs due to excessive protective conductor current or due to fault.
- (v) Mitigate the effects of electromagnetic disturbances.
- (vi) Prevent the indirect energization of a circuit intended to be isolated.

Overload Protection of RCCDs...

These devices have the ability to be overloaded if the combined outgoing current from the final circuits is greater than the rating of the RCCB. Therefore, we provide an 80Amp device as standard with the ability to change this to a 100Amp, or reduce to a 63Amp if required.



(536.4.3.2)

"RCCBs & switches do not provide protection against overload, therefore they shall be protected by an overcurrent protective device."

(536.4.202)

"... overload protection shall not solely be based on the use of diversity factors of the downstream circuits. To achieve overload protection of RCCBs or switches, the rated current of the overcurrent protective device (OCPD) shall be selected according to the manufacturers instructions*."

Comply with the regs...

Regulations 536.4.3.2 and 536.4.202 require the designer to understand the loading profile of the RCCBs within the consumer unit. RCCBs will protect a number of outgoing circuits at the same time.

Method 1

Ensure the full load of all final circuits being protected are less than the rating of the RCCB. The installer will need to consider diversity for the final circuits, but not use diversity as the sole factor for calculating the total current downstream of the device.

Method 2

Ensure the main protective device is of a size to limit the total amount of amps upstream of the devices.

Example 1:

This install would not comply. RCCB1 could be subject to overload.

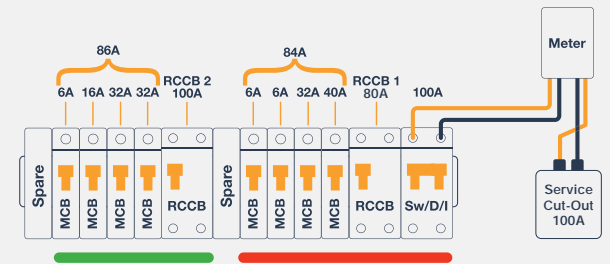

Example 2:

This installation would comply. Although RCCB1 could potentially become overloaded, the protective device at the origin would offer overload protection.

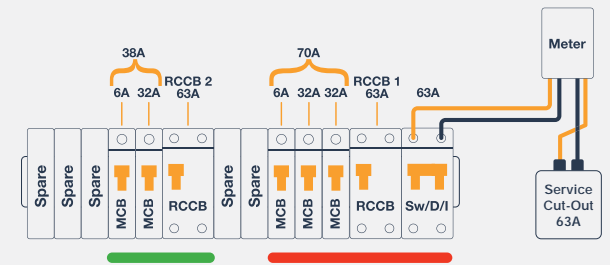

Example 3:

RCBOs offer comprehensive protection as each device is rated to the circuit.

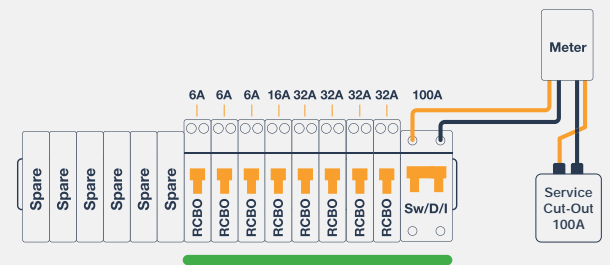

RCD & RCBO

Protective Devices...

RCDs are available in a number of common types; AC, A, F or B. Dependant on the characteristics of the final circuit/s being controlled, the type of RCD selected is very important. If it is believed DC current could be present in the protected circuit/s due to the equipment connected, the designer should select a device capable of working with that DC current present.

General RCDs are designed to operate instantaneously without intentional delay; because of this they are not designed to discriminate in the event of a fault. Therefore, if two general RCDs were to be installed in series, both may operate when a fault presents itself. To avoid this, selectivity is essential between the installed devices to reduce the unintentional operation of a device upstream from the leakage to Earth.

Installing the correct type of device is essential if it is believed DC fault current could be present within the installation. It is important not to install an RCD type that is capable of handling DC fault current ahead of a device that isn't able to operate with these currents.

Such as:

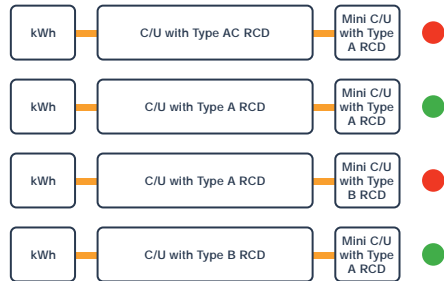

Type A RCD

In today's installations the majority of equipment does have some residual DC current due to the internal electronics. The magnitude of this current can have a detrimental effect on the effectiveness of the protective device. Therefore, we have taken the decision to manufacture Type A devices only.

Type A devices have the ability to continue to work with up to 6mA of DC fault current present. This amount of fault current has been shown to stop AC Type RCDs/RCBOs from working within the maximum time permitted in BS7671.

RCCB - Residual Current Operated Circuit Breaker, without integrated overcurrent protection.



RCBO Protection

These devices combine the functionality of an MCB and RCD into one single device/module. Available as a type A RCD with different inrush curve types B or C, these protective devices have been miniaturised to maximise the available space above for termination or final circuits.

The Neutral fly lead has been made long enough to ensure safe connection to the dedicated Neutral bars.

RCBO - Residual Current Operated Circuit Breaker, with integrated overcurrent protection.



Surge Protection...

Transient Overvoltages

Many installations across the UK have electronic components within them. Surge protection will offer those devices and appliances protection from overvoltage.

Products such as computers, printers, flat screen televisions, alarms, microwaves and washing machines are commonplace. These can all be vulnerable to transient overvoltages, which can significantly reduce the equipment's lifespan through degradation and damage.

A transient overvoltage or surge is a short duration increase in voltage measured between two or more conductors. In short, this means anything from microseconds (millionths of a second) to a few milliseconds (thousandths of a second) in duration.

Example

A domestic consumer unit with 500m of LV supply overhead (L_p) and 500m of supply underground (L_{pc});

$$CRL = f_{env}/(L_p \times N_g)$$

$$CRL = 85 / (2 \times 0.5) \times 0.5$$

$$CRL = 170$$

Which means that surge protection will be required.

Covers Overvoltage Control (443.5)

Calculated risk level (CRL) is used to determine if protection against overvoltages of atmospheric origin is required. The CRL is found by the following formula:

$$CRL = f_{env}/(L_p \times N_g)$$

f_{env} - is an environmental factor selected according to Table 443.1 (Rural/Suburban or Urban)

L_p - is the risk assessment length in km

N_g - is the lightning ground flash density (flashes per km² per year) relevant to the location of the power line and connected structure (see figure 44.2).

If the CRL value is less than 1000 then SPD protection should be installed. If the CRL value is 1000 or more then SPD protection is not required.

Covers Overvoltage Control (443.4)

Protection against overvoltages shall be provided where the consequence caused by overvoltage could:

- (i) Result in serious injury to, or loss of, human life.
- (ii) Result in the interruption of public services and/or damage to cultural heritage.
- (iii) Result in interruption of commercial or industrial activity.
- (iv) Affect a large number of co-located individuals.

For all other cases, a risk assessment according to regulation 443.5 shall be performed to determine if protection against transient over-voltage is required. If the risk assessment is not performed, the electrical installation shall be provided with protection against transient over-voltages, except for single dwelling units where the total value of the installation and equipment therein does not justify such protection.

Protection against switching overvoltages shall be considered in the case of equipment likely to produce switching overvoltages or disturbances exceeding the values according to the voltage category of the installation, e.g. where an LV generator supplies the installation or where inductive or capacitive loads (e.g. motors, transformers, capacitor banks) storage units or high-current loads are installed.



SPD Type 2

SPD which can prevent the spread of over-voltages in the electrical installations and protects equipment connected to it. It usually employs metal oxide varistor (MOV) technology and is characterised by an 8/20 μ s current wave.

Terminology

I_{imp} - Impulse current of 10/350 μ s waveform.

I_n - Surge current of 8/20 μ s waveform associated with Type 2 SPDs.

U_p - The residual voltage that is measured across the terminal of the SPD when I_n is applied.

U_c - The maximum voltage which may be continuously applied to the SPD without it conducting.

I_{max} - Maximum short circuit current of the device.



Consumer Units



Functional, stylish, and innovative, our Elucian range of consumer units provides an exceptional option for any residential or light commercial environment. Packed with features making installation quick and simple for electricians, with a clear labelling kit for easy identification for the customer. A great range of configurations and sizes makes Elucian perfect for any installation requirement.

Features & Benefits...



Metal Consumer Units

All Elucian consumer units are constructed using non combustible and robust metal housings. They ensure compliance against the third amendment which was added to the BS 7671 wiring regulations in 2015 requiring consumer units in domestic premises to have a non-combustible enclosure.



Mains Switch Tail Clamp

Each consumer and mini unit come supplied and pre-fitted with a Mains Switch Tail Clamp for added stress relief to ensure the Mains Tail terminations do not come loose and to help fix the Mains Switch Isolator more securely to prevent any rocking or movement. The Mains Switch Tail Clamp will accept a maximum of 25mm² double insulated tails.

Retrofit Locking Device

Can be installed on the left or right of the enclosure.



Variable Knockout Sizes

The units all come supplied with a wide range of 40mm, 32mm, 25mm and 20mm knockouts making each board universally adaptable for all installation and cable types.



Rear Knockouts

The units also come supplied with rear knockouts to provide ample cabling capacity for any installation type. Each knockout will be supplied with a 0.5M grommet strip to allow a smooth entry into the board, protecting cable from any potential sharp edges.



Shrouded Live Bus Bar

Our live bus bar comes supplied with the shroud pre-fitted for extra safety and convenience. Our Neutral and Earth Bus Bars are supplied with backed off screws allowing a faster installation



Accessories Pack

Contains a Sticker Set for clear circuit identification and caution warnings, Grommet Knockout Strips, 2 x Blank Modules, a detailed instruction sheet for all recommended installation details and a Live Bus Bar, Cover and Caps for added insulation and installation completion.

Consumer Unit Breakdown...

Torque Rating Label

There is a handy Torque rating label inside every consumer unit, allowing you to make all terminations with ease.

Grommet Strip

Each knockout will be supplied with a 0.5M grommet strip to allow a smooth entry into the board, protecting cable from any potential sharp edges.

Compact RCBOs

The latest design in compact RCBOs leaves more than sufficient space for cabling and terminating.

Keyway DIN Rail

A fast release Keyway DIN Rail allows for ease of installation.

MCB Style Solid Blanks

These are DIN Rail mountable and can only be removed when the cover is removed, thus providing additional safety. Other types of blanks can easily fall out or become dislodged.

Large Space for Wiring

Each consumer unit has a large space for wiring, suitable for the increasing demands and circuit ways on a consumer unit.

Non-Combustible Enclosures

Non-combustible and robust metal housings ensure compliance against the third amendment added to the BS 7671 wiring regulations.

Earth and Neutral Bar

Each unit has its own specifically configured Earth and Neutral Bar to allow for best practice installation of each board type.

Lock Off Capabilities

Lockout devices are designed to attach to the moving part of the protective device, usually a switch toggle (rocker switch) which moves from the on to off position.

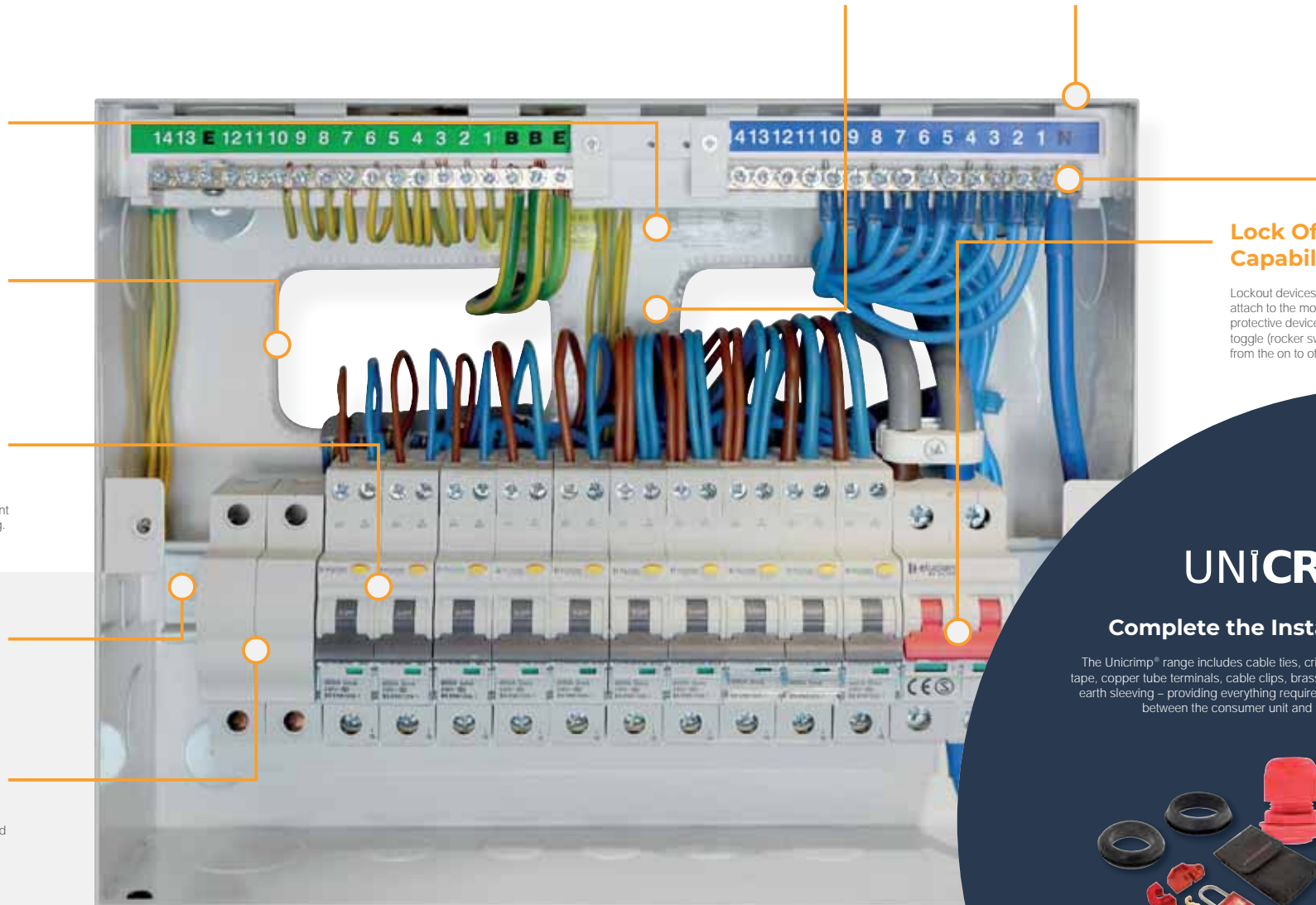

UNICRIMP®

Complete the Installation...

The Unicrimp® range includes cable ties, crimp terminals, PVC tape, copper tube terminals, cable clips, brass/nylon glands and earth sleeving – providing everything required to harness cable between the consumer unit and the end accessory.





Mini Units (Garage)



RCD Fitted



Tail Clamp
Pre-Installed



Mini Units (Garage)

- GUEB563RCD3** 5 Way Unit with 63A 30mA RCD (3 Free Ways)
- GUEB580RCD3** 5 Way Unit with 80A 30mA RCD (3 Free Ways)

Supplied with complete complement of earth and neutral terminals along with marking labels, busbar and instruction leaflet.

Warranty (Years): 10
Warranty - Devices (Years): 3
Standards: BS EN 61439-3 BS EN 61008-1
Dimensions (mm): 168 (W) x 260 (H) x 115 (D)



Straight
Mains Board



Mains
Switch Fitted



Tail Clamp
Pre-Installed

Supplied with complete complement of earth and neutral terminals along with marking labels, busbar and instruction leaflet.

Switch-Disconnecter Units

- CUEB8MS6** 8 Way Unit with 100A Mains Switch (6 Free Ways)
- CUEB10MS8** 10 Way Unit with 100A Mains Switch (8 Free Ways)
- CUEB12MS10** 12 Way Unit with 100A Mains Switch (10 Free Ways)
- CUEB14MS12** 14 Way Unit with 100A Mains Switch (12 Free Ways)
- CUEB16MS14** 16 Way Unit with 100A Mains Switch (14 Free Ways)
- CUEB18MS16** 18 Way Unit with 100A Mains Switch (16 Free Ways)
- CUEB22MS20** 22 Way Unit with 100A Mains Switch (20 Free Ways)

Warranty (Years): 10
 Warranty - Devices (Years): 3
 Standards: BS EN 61439-3 BS EN 60947-3
 Dimensions (mm): 8 Way: 222 (W) x 260 (H) x 115 (D) 10 Way: 258 (W) x 260 (H) x 115 (D)
 12 Way: 294 (W) x 260 (H) x 115 (D) 14 Way: 330 (W) x 260 (H) x 115 (D) 16 Way: 366 (W) x 260 (H) x 115 (D)
 18 Way: 402 (W) x 260 (H) x 115 (D) 22 Way: 474 (W) x 260 (H) x 115 (D)



Straight
Mains Board



Mains
Switch Fitted



Tail Clamp
Pre-Installed



SPD Fitted

Supplied with complete complement of earth and neutral terminals along with marking labels, busbar and instruction leaflet.

Switch-Disconnecter Units Including Surge Protection

- CUEB10MSSP6** 10 Way Unit with 100A Mains Switch & SPD (6 Free Ways)
- CUEB12MSSP8** 12 Way Unit with 100A Mains Switch & SPD (8 Free Ways)
- CUEB14MSSP10** 14 Way Unit with 100A Mains Switch & SPD (10 Free Ways)
- CUEB16MSSP12** 16 Way Unit with 100A Mains Switch & SPD (12 Free Ways)
- CUEB18MSSP14** 18 Way Unit with 100A Mains Switch & SPD (14 Free Ways)
- CUEB22MSSP18** 22 Way Unit with 100A Mains Switch & SPD (18 Free Ways)

Warranty (Years): 10
 Warranty - Devices (Years): 3
 Standards: BS EN 61439-3 BS EN 60947-3 BS EN 61643-1-11
 Dimensions (mm): 10 Way: 258 (W) x 260 (H) x 115 (D) 12 Way: 294 (W) x 260 (H) x 115 (D) 14 Way: 330 (W) x 260 (H) x 115 (D)
 16 Way: 366 (W) x 260 (H) x 115 (D) 18 Way: 402 (W) x 260 (H) x 115 (D) 22 Way: 474 (W) x 260 (H) x 115 (D)



Split Load Board



Mains Switch Fitted



Tail Clamp Pre-Installed



RCD Fitted



Supplied with complete complement of earth and neutral terminals along with marking labels, busbar and instruction leaflet.

Split Load Units

- CUEB14MSRCD8** 14 Way Unit with 100A Mains Switch + 2 x 80A 30mA RCD (4+4 Free Ways)
- CUEB16MSRCD10** 16 Way Unit with 100A Mains Switch + 2 x 80A 30mA RCD (5+5 Free Ways)
- CUEB18MSRCD12** 18 Way Unit with 100A Mains Switch + 2 x 80A 30mA RCD (6+6 Free Ways)
- CUEB22MSRCD16** 22 Way Unit with 100A Mains Switch + 2 x 80A 30mA RCD (8+8 Free Ways)

Warranty (Years): 10
 Warranty - Devices (Years): 3
 Standards: BS EN 61439-3 BS EN 60947-3 BS EN 61008-1
 Dimensions (mm): 14 Way: 330 (W) x 260 (H) x 115 (D) 16 Way: 366 (W) x 260 (H) x 115 (D) 18 Way: 402 (W) x 260 (H) x 115 (D) 22 Way: 474 (W) x 260 (H) x 115 (D)



Split Load Board With Surge Protection



Mains Switch Fitted



Tail Clamp Pre-Installed



RCD Fitted



SPD Fitted

Supplied with complete complement of earth and neutral terminals along with marking labels, busbar and instruction leaflet.

Split Load Units Including Surge Protection

- CUEB14MSRCDSP6** 14 Way Unit with 100A Mains Switch + 2 x 80A 30mA RCD + 2 Pole SPD (3+3 Free Ways)
- CUEB16MSRCDSP8** 16 Way Unit with 100A Mains Switch + 2 x 80A 30mA RCD + 2 Pole SPD (4+4 Free Ways)
- CUEB18MSRCDSP10** 18 Way Unit with 100A Mains Switch + 2 x 80A 30mA RCD + 2 Pole SPD (5+5 Free Ways)
- CUEB22MSRCDSP14** 22 Way Unit with 100A Mains Switch + 2 x 80A 30mA RCD + 2 Pole SPD (7+7 Free Ways)

Warranty (Years): 10
 Warranty - Devices (Years): 3
 Standards: BS EN 61439-3 BS EN 60947-3 BS EN 61008-1 BS EN 61643-1-11
 Dimensions (mm): 14 Way: 330 (W) x 260 (H) x 115 (D) 16 Way: 366 (W) x 260 (H) x 115 (D) 18 Way: 402 (W) x 260 (H) x 115 (D) 22 Way: 474 (W) x 260 (H) x 115 (D)



High Integrity Board



Mains Switch Fitted



Tail Clamp Pre-Installed



RCD Fitted



Supplied with complete complement of earth and neutral terminals along with marking labels, busbar and instruction leaflet.

Combination Units (High Integrity)

- CUEHIB14MSRCD8** 14 Way Unit with 100A Mains Switch + 2 x 80A RCD (8 Free Ways)
- CUEHIB16MSRCD10** 16 Way Unit with 100A Mains Switch + 2 x 80A RCD (10 Free Ways)
- CUEHIB18MSRCD12** 18 Way Unit with 100A Mains Switch + 2 x 80A RCD (12 Free Ways)
- CUEHIB22MSRCD16** 22 Way Unit with 100A Mains Switch + 2 x 80A RCD (16 Free Ways)

Warranty (Years): 10
 Warranty - Devices (Years): 3
 Standards: BS EN 61439-3 BS EN 60947-3 BS EN 61008-1
 Dimensions (mm): 14 Way: 330 (W) x 260 (H) x 115 (D) 16 Way: 366 (W) x 260 (H) x 115 (D) 18 Way: 402 (W) x 260 (H) x 115 (D) 22 Way: 474 (W) x 260 (H) x 115 (D)



High Integrity Board



Mains Switch Fitted



Tail Clamp Pre-Installed



RCD Fitted



SPD Fitted

Supplied with complete complement of earth and neutral terminals along with marking labels, busbar and instruction leaflet.

Combination Units (High Integrity) Including Surge Protection

- CUEHIB14MSRCDSP6** 14 Way Unit with 100A Mains Switch + 2 x 80A RCD & SPD (6 Free Ways)
- CUEHIB16MSRCDSP8** 16 Way Unit with 100A Mains Switch + 2 x 80A RCD & SPD (8 Free Ways)
- CUEHIB18MSRCDSP10** 18 Way Unit with 100A Mains Switch + 2 x 80A RCD & SPD (10 Free Ways)
- CUEHIB22MSRCDSP14** 22 Way Unit with 100A Mains Switch + 2 x 80A RCD & SPD (14 Free Ways)

Warranty (Years): 10
 Warranty - Devices (Years): 3
 Standards: BS EN 61439-3 BS EN 60947-3 BS EN 61008-1 BS EN 61643-1-11
 Dimensions (mm): 14 Way: 330 (W) x 260 (H) x 115 (D) 16 Way: 366 (W) x 260 (H) x 115 (D) 18 Way: 402 (W) x 260 (H) x 115 (D) 22 Way: 474 (W) x 260 (H) x 115 (D)

Protective Devices

Our Elucian range of Protective Devices are easy to install, suitable for residential and light commercial environments, they provide protection against earth faults to ensure people's safety against electrocution and fires.



Features & Benefits...

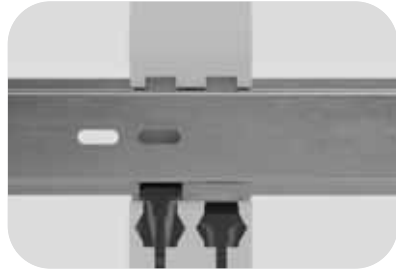

Clip in Devices

The Elucian Protective Devices simply click onto the DIN Rail and can be secured with this locking mechanism. This means work can be carried out quicker and without dealing with tight spaces.



Lock Off Capabilities

Lockout devices (available at Unicrimp®) are designed to attach to the moving part of the protective device, usually a switch toggle (rocker switch) which moves from the on to off position. This ensures the switch cannot be switched back on while work is being carried out.



Clear Indication

Each protective device has clear and visible trip indication along with clear product information which is easily visible whatever the switch position.



3 Year Product Warranty

We take pride in leading the market and our 3 year warranty offers the best peace of mind available as standard today. It reflects the confidence we have in our products and the benefit of years of continuous engineering improvement.



Lockable switch (with compatible kit)
Thermal / Magnetic Trip Release



B curve

MCB's Single Pole B Curve

- CU1MCB6B 6A B Curve True 6kA MCB
- CU1MCB10B 10A B Curve True 6kA MCB
- CU1MCB16B 16A B Curve True 6kA MCB
- CU1MCB20B 20A B Curve True 6kA MCB
- CU1MCB25B 25A B Curve True 6kA MCB
- CU1MCB32B 32A B Curve True 6kA MCB
- CU1MCB40B 40A B Curve True 6kA MCB
- CU1MCB50B 50A B Curve True 6kA MCB
- CU1MCB63B 63A B Curve True 6kA MCB



C curve

MCB's Single Pole C Curve

- CU1MCB6C 6A C Curve True 6kA MCB
- CU1MCB10C 10A C Curve True 6kA MCB
- CU1MCB16C 16A C Curve True 6kA MCB
- CU1MCB20C 20A C Curve True 6kA MCB
- CU1MCB25C 25A C Curve True 6kA MCB
- CU1MCB32C 32A C Curve True 6kA MCB
- CU1MCB40C 40A C Curve True 6kA MCB
- CU1MCB50C 50A C Curve True 6kA MCB
- CU1MCB63C 63A C Curve True 6kA MCB



Single Pole



True 6kA



Large Terminal Capacity

Warranty (Years): 3
Standards: BS EN 60898-1
Dimensions (mm): 17.8 (W) x 85.3 (H) x 76.6 (D)



Lockable switch (with compatible kit)



B curve

RCBO's Type A Single Pole B Curve

- CU1RCBO6B** 6A 30mA B Curve True 6kA RCBO
- CU1RCBO10B** 10A 30mA B Curve True 6kA RCBO
- CU1RCBO16B** 16A 30mA B Curve True 6kA RCBO
- CU1RCBO20B** 20A 30mA B Curve True 6kA RCBO
- CU1RCBO32B** 32A 30mA B Curve True 6kA RCBO
- CU1RCBO40B** 40A 30mA B Curve True 6kA RCBO



C curve

RCBO's Type A Single Pole C Curve

- CU1RCBO6C** 6A 30mA C Curve True 6kA RCBO
- CU1RCBO10C** 10A 30mA C Curve True 6kA RCBO
- CU1RCBO16C** 16A 30mA C Curve True 6kA RCBO
- CU1RCBO20C** 20A 30mA C Curve True 6kA RCBO
- CU1RCBO32C** 32A 30mA C Curve True 6kA RCBO
- CU1RCBO40C** 40A 30mA C Curve True 6kA RCBO



Type A



Trip Current



Large Terminal Capacity



True 6kA



Single Pole + Neutral

Warranty (Years): 3
 Standards: BS EN 61009-1
 Neutral Flylead (mm): 450
 Dimensions (mm): 17.8 (W) x 91.8 (H) x 76.6 (D)



Lockable switch (with compatible kit)



B curve

RCBO's Type A 2 Module Double Pole B Curve

- CU2RCBO45B** 45A 30mA B Curve True 6kA RCBO
- CU2RCBO50B** 50A 30mA B Curve True 6kA RCBO
- CU2RCBO63B** 63A 30mA B Curve True 6kA RCBO



C curve

RCBO's Type A 2 Module Double Pole C Curve

- CU2RCBO45C** 45A 30mA C Curve True 6kA RCBO
- CU2RCBO50C** 50A 30mA C Curve True 6kA RCBO
- CU2RCBO63C** 63A 30mA C Curve True 6kA RCBO



Type A



Trip Current



Large Terminal Capacity



True 6kA



Single Pole + Neutral

Warranty (Years): 3
 Standards: BS EN 61009-1
 Dimensions (mm): 35.6 (W) x 84 (H) x 76.6 (D)

B32



Lockable switch (with compatible kit)

RCD's

- CU2RCD63A** 63A 30mA 2 Pole RCD
- CU2RCD80A** 80A 30mA 2 Pole RCD
- CU2RCD100A** 100A 30mA 2 Pole RCD

Time Delay RCD's

- CU2RCDTD63A** 63A 100mA 2 Pole Time Delay RCD
- CU2RCDTD80A** 80A 100mA 2 Pole Time Delay RCD
- CU2RCDTD100A** 100A 100mA 2 Pole Time Delay RCD



Warranty (Years): 3
 Standards: BS EN 61008-1
 Dimensions (mm): 35.5 (W) x 85.2 (H) x 73 (D) 100: 35.6 (W) x 87 (H) x 74 (D)

B33



Cartridge Replaceable For L&N (Product Ref.CU2SPDC275)

SPD's

- CU2SPD275T** 40kA 275Uc (V-) 2 Pole Type 2 SPD with Tails

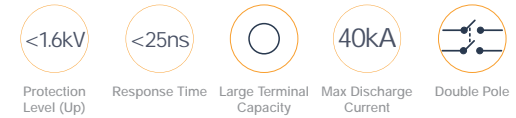

Warranty (Years): 3
 Standards: BS EN 61643-1-11
 Dimensions (mm): 36 (W) x 90 (H) x 70 (D)



Lockable switch (with compatible kit)

Mains Switch-Disconnecter
CU2MS100 100A 2 Pole Disconnecter-Switch

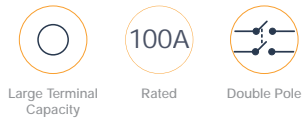

Warranty (Years): 3
 Standards: BS EN 60947-3
 Dimensions (mm): 35.9 (W) x 85.3 (H) x 76.6 (D)



Single MCB Width
 Clips On To DIN Rail

Blank Modules
CU1BLANK Single Way Din Rail Blank Module

Warranty (Years): 3
 Dimensions (mm): 18 (W) x 81 (H) x 70 (D)



DB700 | DB750



DB701 | DB751

Suitable for use with CLICK DB981 cable shroud



Fused Main Switch

- DB700** 80A Fused Main Switch (80A HRC Fuse Fitted)
- DB701** 80A Fused Main Switch (80A HRC Fuse Fitted) - Lockable
- DB750** 100A Fused Main Switch (80A HRC Fuse Fitted)
- DB751** 100A Fused Main Switch (80A HRC Fuse Fitted) - Lockable



HRC fuse supplied

Standards: BS 60947-03
 Cable Size (mm²): 700 701: 25 & 16 750 751: 35 & 25
 Dimensions (mm): 700 701: 127.5 (W) x 53.5 (D) x 80.5 (H) 750 751: 133 (W) x 60 (D) x 101 (H)



DB790 | DB791

DB981

Fused Main Switch Accessories

- DB790** Metal Enclosure for Fused Main Switch (DB700/701)
 Suitable for DB700/701 80A fused main switch
- DB791** Metal Enclosure for Fused Main Switch (DB750/751)
 Suitable for DB701/751 100A fused main switch
- DB981** Elongated Cable Shroud (Packaged Individually)
 Enables surface and rear entry cable access
 Suitable for use with the Fused Main Switch range (DB700, DB701, DB750 & DB751)

Cable Size (mm²): 790: 25 & 16 791: 981: 35
 Dimensions (mm): 790 791: 168 (W) x 94.5 (D) x 133 (H) 981: 80 (W) x 90 (D) x 45 (H)

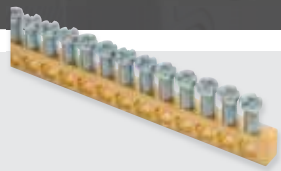

Terminal Bar



Support Clip & Screws

Terminal Bars

CUTB4	4 Way Terminal Bar	CUTB17	17 Way Terminal Bar
CUTB6	6 Way Terminal Bar	CUTB18	18 Way Terminal Bar
CUTB7	7 Way Terminal Bar	CUTB19	19 Way Terminal Bar
CUTB8	8 Way Terminal Bar	CUTB20	20 Way Terminal Bar
CUTB9	9 Way Terminal Bar	CUTB22	22 Way Terminal Bar
CUTB10	10 Way Terminal Bar	CUTB23	23 Way Terminal Bar
CUTB12	12 Way Terminal Bar	CUTB26	26 Way Terminal Bar
CUTB15	15 Way Terminal Bar	CUTBSC	Terminal Bar Support Clip & Screws (PK5)
CUTB16	16 Way Terminal Bar	CUTBSCSL	Split Load Terminal Bar Support Clip & Screws (PK 5)

*All accessories are for use on Elucian Consumer Units only and are not suitable for Consumer Unit conversions.

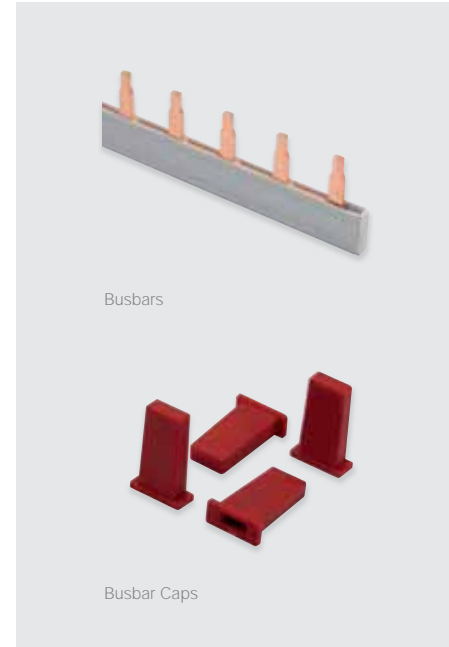

Busbars

Busbar Caps

Busbar & Cover Sets

CUBUS3	3 Way Busbar & Cover Set
CUBUS4	4 Way Busbar & Cover Set
CUBUS5	5 Way Busbar & Cover Set
CUBUS6	6 Way Busbar & Cover Set
CUBUS7	7 Way Busbar & Cover Set
CUBUS8	8 Way Busbar & Cover Set
CUBUS12	12 Way Busbar & Cover Set
CUBUS20	20 Way Busbar & Cover Set
CUCAP	Busbar Caps (PK 10)



DIN Rail

DIN Rails

CUDR10	10 Way DIN Rail
CUDR12	12 Way DIN Rail
CUDR14	14 Way DIN Rail
CUDR16	16 Way DIN Rail
CUDR18	18 Way DIN Rail
CUDR22	22 Way DIN Rail

*All accessories are for use on Elucian Consumer Units only and are not suitable for Consumer Unit conversions.



SPD Cartridge

SPD Cartridge
CU2SPDC275 275V – 40kA SPD Cartridge
 *Replacement for both live and neutral sides.



Retrofit Locking Device

Retrofit Locking Device
CUELOCK Retrofit Locking Device
 Can be installed on the left or right of the enclosure. Padlock not supplied



Neutral Link Cable

Link Cables
CUCNL210 Neutral Link Cable (210mm)
CUCNL285 Neutral Link Cable (285mm)



Combined Live Link Cable

CUCNL325 Neutral Link Cable (325mm)
CUCLL Combined Live Link Cable (285mm & 355mm)

*All accessories are for use on Elucian Consumer Units only and are not suitable for Consumer Unit conversions.

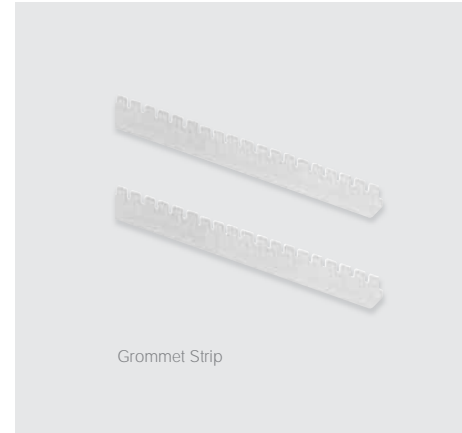

Grommet Strip

Grommet Strip
CUGS1 500mm Grommet Strip (PK 3)



Mains Clamp & Screw

Mains Cable Clamp Components
CUCLAMP Mains Cable Clamp & Screw



Mains Clamp Plate

Mains Cable Clamp Components
CUPLATE Mains Cable Clamp Plate

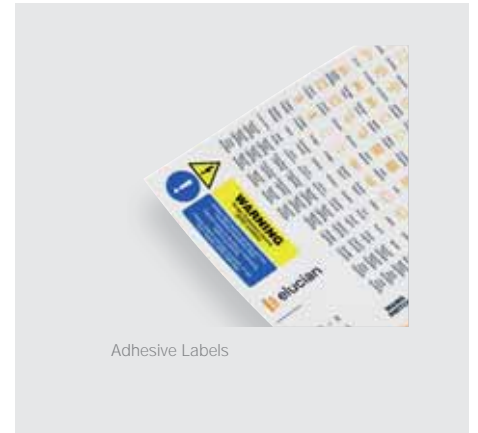

Adhesive Labels

Adhesive Labels
CULAB1 Set of Adhesive Labels

*All accessories are for use on Elucian Consumer Units only and are not suitable for Consumer Unit conversions.

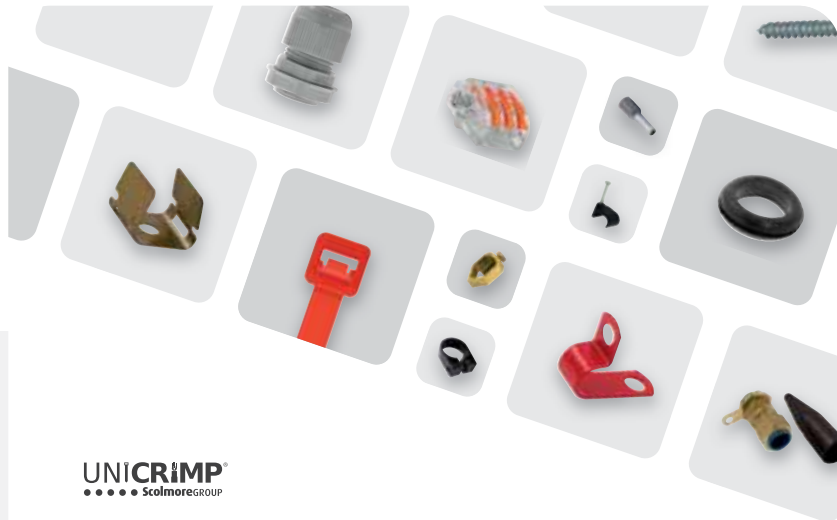

UNICRIMP®
 ●●●●● ScolmoreGROUP

The Unicrimp® range includes cable ties, crimp terminals, PVC tape, copper tube terminals, cable clips, and brass and nylon glands – providing everything required to harness cable between the consumer unit and the end accessory.

For more information check out the latest Unicrimp® Electrical accessories catalogue or visit unicrimp.com

Complete the Installation



Grommets

Standard and quick fit grommets available in 20mm and 25mm



Lock Off Kit

Basic and contractor Lock Off Kits available.

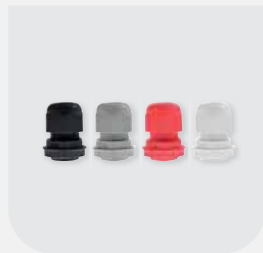

Nylon Glands

Available in black, grey, red & white in sizes ranging from 12mm-63mm

Technical Information

All the technical information and mounting dimensions you will need for your Elucian Consumer Units and Protective Devices.



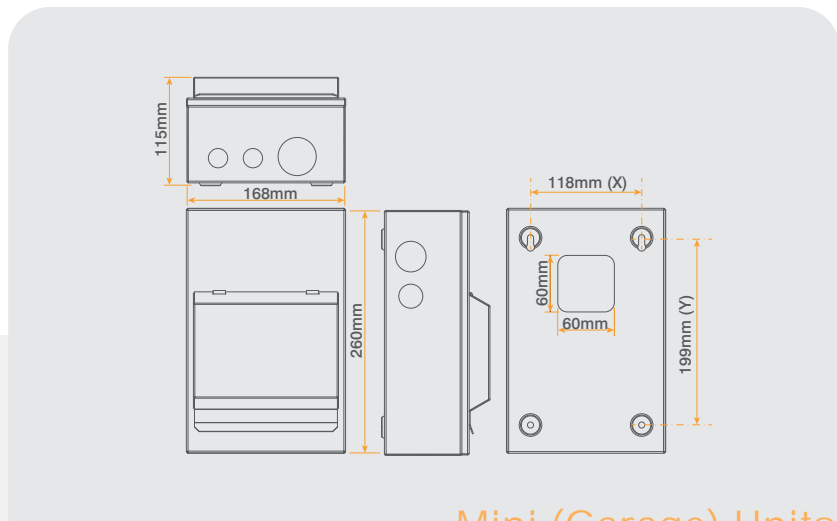

Mini (Garage) Units

Board Product Code	GUEB563RCD3	GUEB580RCD3
Ingress Protection	IP20	
IK Rating	IK05	
Operational Temperature (°C)	-5 to +40	
Tail Clamp Capacity (mm ²)	25	
Tail Clamp Torque (Nm)	1.5	
CPC & N Bars Capacity (mm ²)	16	
CPC & N Bars Torque (Nm)	2	
Switch-Disconnecter Fitted	-	-
RCD Fitted	1 x 63A 30mA RCD (CU2RCD63A)	1 x 80A 30mA RCD (CU2RCD80A)
SPD Fitted	-	-
Free Ways	3	3
Nett Weight	2.9kg	2.9kg

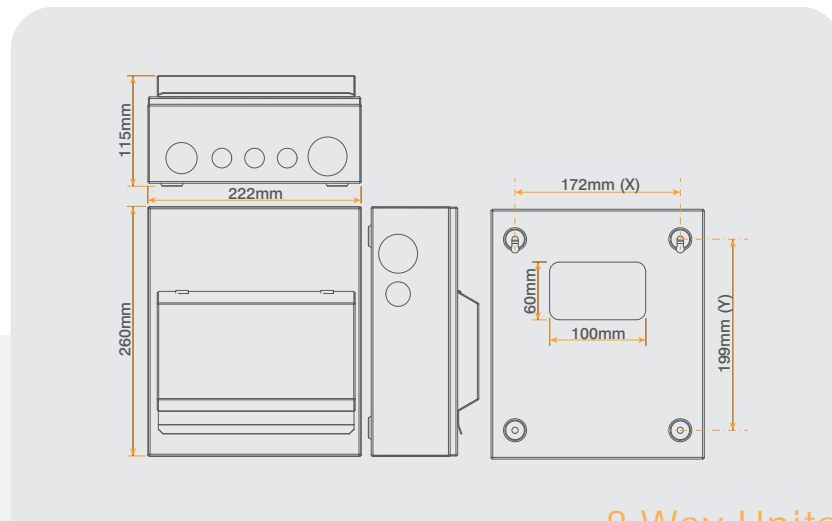

8 Way Units

Board Product Code	CUEB8MS6
Ingress Protection	IP20
IK Rating	IK05
Operational Temperature (°C)	-5 to +40
Tail Clamp Capacity (mm ²)	25
Tail Clamp Torque (Nm)	1.5
CPC & N Bars Capacity (mm ²)	16
CPC & N Bars Torque (Nm)	2
Switch-Disconnecter Fitted	1 x 100A (CU2MS100)
RCD Fitted	-
SPD Fitted	-
Free Ways	6
Nett Weight	3.3kg

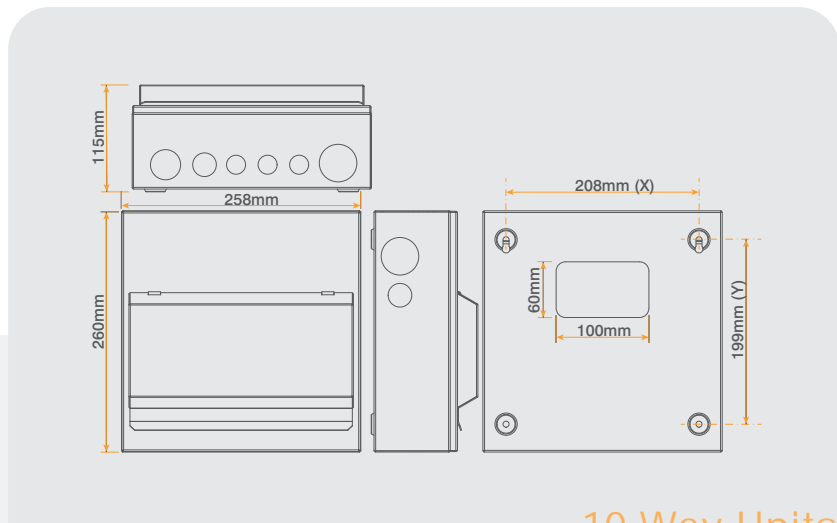

10 Way Units

Board Product Code	CUEB10MS8	CUEB10MSSP6
Ingress Protection	IP20	IP20
IK Rating	IK05	IK05
Operational Temperature (°C)	-5 to +40	-5 to +40
Tail Clamp Capacity (mm ²)	25	25
Tail Clamp Torque (Nm)	1.5	1.5
CPC & N Bars Capacity (mm ²)	16	16
CPC & N Bars Torque (Nm)	2	2
Switch-Disconnecter Fitted	1 x 100A (CU2MS100)	1 x 100A (CU2MS100)
RCD Fitted	-	-
SPD Fitted	-	1 x 40kA SPD (CU2SPD275)
Free Ways	8	6
Nett Weight	3.6kg	3.86Kg

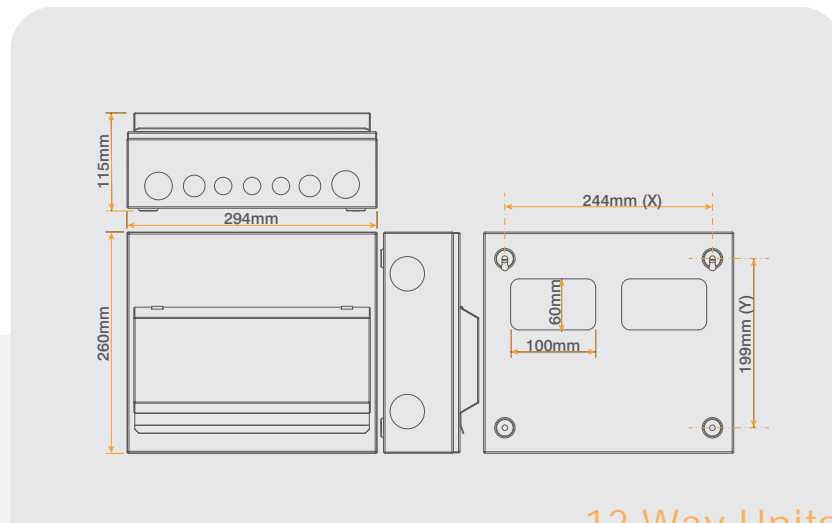

12 Way Units

Board Product Code	CUEB12MS10	CUEB12MSSP8
Ingress Protection	IP20	IP20
IK Rating	IK05	IK05
Operational Temperature (°C)	-5 to +40	-5 to +40
Tail Clamp Capacity (mm ²)	25	25
Tail Clamp Torque (Nm)	1.5	1.5
CPC & N Bars Capacity (mm ²)	16	16
CPC & N Bars Torque (Nm)	2	2
Switch-Disconnecter Fitted	1 x 100A (CU2MS100)	1 x 100A (CU2MS100)
RCD Fitted	-	-
SPD Fitted	-	1 x 40kA SPD (CU2SPD275)
Free Ways	10	8
Nett Weight	3.9kg	4.16Kg

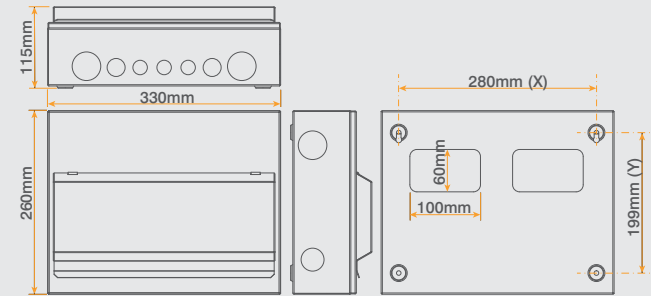

14 Way Units

Board Product Code	CUEB14MS12	CUEB14MSRCD8	CUEB14MSRCDSP6		Board Product Code	CUEHIB14MSRCD8	CUEB14MSSP10	CUEHIB14MSRCDSP6
Ingress Protection	IP20	IP20	IP20		Ingress Protection	IP20	IP20	IP20
IK Rating	IK05	IK05	IK05		IK Rating	IK05	IK05	IK05
Operational Temperature (°C)	-5 to +40	-5 to +40	-5 to +40		Operational Temperature (°C)	-5 to +40	-5 to +40	-5 to +40
Tail Clamp Capacity (mm ²)	25	25	25		Tail Clamp Capacity (mm ²)	25	25	25
Tail Clamp Torque (Nm)	1.5	1.5	1.5		Tail Clamp Torque (Nm)	1.5	1.5	1.5
CPC & N Bars Capacity (mm ²)	16	16	16		CPC & N Bars Capacity (mm ²)	16	16	16
CPC & N Bars Torque (Nm)	2	2	2		CPC & N Bars Torque (Nm)	2	2	2
Switch-Disconnecter Fitted	1 x 100A (CU2MS100)	1 x 100A (CU2MS100)	1 x 100A (CU2MS100)		Switch-Disconnecter Fitted	1 x 100A (CU2MS100)	1 x 100A (CU2MS100)	1 x 100A (CU2MS100)
RCD Fitted	-	2 x 80A 30mA RCD (CU2RCD80A)	2 x 80A 30mA RCD (CU2RCD80A)		RCD Fitted	2 x 80A 30mA RCD (CU2RCD80A)	1 x 40kA SPD (CU2SPD275)	2 x 80A 30mA RCD (CU2RCD80A)
SPD Fitted	-	-	1 x 40kA SPD (CU2SPD275)		SPD Fitted	-	-	1 x 40kA SPD (CU2SPD275)
Free Ways	12	8 (4+4)	6 (3+3)		Free Ways	8	10	6
Nett Weight	4.3kg	5.2kg	5.4kg		Nett Weight	5.2kg	4.56Kg	5.46Kg

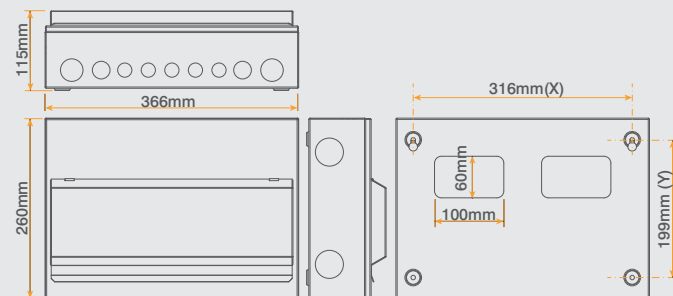

16 Way Units

Board Product Code	CUEB16MS14	CUEB16MSRCD10	CUEB16MSRCDSP8	Board Product Code	CUEHIB16MSRCD10	CUEB16MSSP12	CUEHIB16MSRCDSP8
Ingress Protection	IP20	IP20	IP20	Ingress Protection	IP20	IP20	IP20
IK Rating	IK05	IK05	IK05	IK Rating	IK05	IK05	IK05
Operational Temperature (°C)	-5 to +40	-5 to +40	-5 to +40	Operational Temperature (°C)	-5 to +40	-5 to +40	-5 to +40
Tail Clamp Capacity (mm ²)	25	25	25	Tail Clamp Capacity (mm ²)	25	25	25
Tail Clamp Torque (Nm)	1.5	1.5	1.5	Tail Clamp Torque (Nm)	1.5	1.5	1.5
CPC & N Bars Capacity (mm ²)	16	16	16	CPC & N Bars Capacity (mm ²)	16	16	16
CPC & N Bars Torque (Nm)	2	2	2	CPC & N Bars Torque (Nm)	2	2	2
Switch-Disconnecter Fitted	1 x 100A (CU2MS100)	1 x 100A (CU2MS100)	1 x 100A (CU2MS100)	Switch-Disconnecter Fitted	1 x 100A (CU2MS100)	1 x 100A (CU2MS100)	1 x 100A (CU2MS100)
RCD Fitted	-	2 x 80A 30mA RCD (CU2RCD80A)	2 x 80A 30mA RCD (CU2RCD80A)	RCD Fitted	2 x 80A 30mA RCD (CU2RCD80A)	-	2 x 80A 30mA RCD (CU2RCD80A)
SPD Fitted	-	-	1 x 40kA SPD (CU2SPD275)	SPD Fitted	-	1 x 40kA SPD (CU2SPD275)	1 x 40kA SPD (CU2SPD275)
Free Ways	14	10 (5+5)	8 (4+4)	Free Ways	10	12	8
Nett Weight	4.5kg	5.4kg	5.6kg	Nett Weight	5.4kg	4.76Kg	5.61Kg

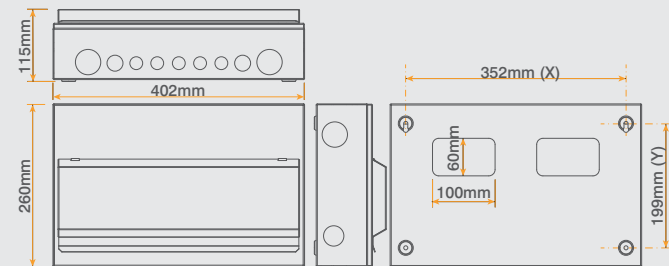

18 Way Units

Board Product Code	CUEB18MS16	CUEB18MSRCD12	CUEB18MSRCDSP10	Board Product Code	CUEHIB18MSRCD12	CUEB18MSSP14	CUEHIB18MSRCDSP10
Ingress Protection	IP20	IP20	IP20	Ingress Protection	IP20	IP20	IP20
IK Rating	IK05	IK05	IK05	IK Rating	IK05	IK05	IK05
Operational Temperature (°C)	-5 to +40	-5 to +40	-5 to +40	Operational Temperature (°C)	-5 to +40	-5 to +40	-5 to +40
Tail Clamp Capacity (mm ²)	25	25	25	Tail Clamp Capacity (mm ²)	25	25	25
Tail Clamp Torque (Nm)	1.2Nm Max	1.2Nm Max	1.2Nm Max	Tail Clamp Torque (Nm)	1.2Nm Max	1.5	1.5
CPC & N Bars Capacity (mm ²)	16	16	16	CPC & N Bars Capacity (mm ²)	16	16	16
CPC & N Bars Torque (Nm)	2	2	2	CPC & N Bars Torque (Nm)	2	2	2
Switch-Disconnecter Fitted	1 x 100A (CU2MS100)	1 x 100A (CU2MS100)	1 x 100A (CU2MS100)	Switch-Disconnecter Fitted	1 x 100A (CU2MS100)	1 x 100A (CU2MS100)	1 x 100A (CU2MS100)
RCD Fitted	-	2 x 80A 30mA RCD (CU2RCD80A)	2 x 80A 30mA RCD (CU2RCD80A)	RCD Fitted	2 x 80A 30mA RCD (CU2RCD80A)	-	2 x 80A 30mA RCD (CU2RCD80A)
SPD Fitted	-	-	1 x 40kA SPD (CU2SPD275)	SPD Fitted	-	1 x 40kA SPD (CU2SPD275)	1 x 40kA SPD (CU2SPD275)
Free Ways	16	12 (6+6)	10 (5+5)	Free Ways	12	14	10
Nett Weight	4.7kg	5.5kg	5.7kg	Nett Weight	5.5kg	4.96Kg	5.76Kg

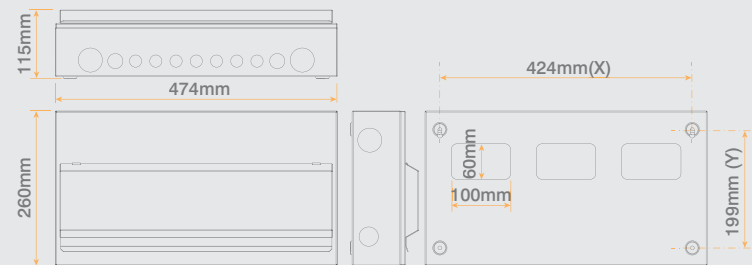

22 Way Units

Board Product Code	CUEB22MS20	CUEB22MSRCD16	CUEB22MSRCDSP14		Board Product Code	CUEHIB22MSRCD16	CUEB22MSSP18	CUEHIB22MSRCDSP14
Ingress Protection	IP20	IP20	IP20		Ingress Protection	IP20	IP20	IP20
IK Rating	IK05	IK05	IK05		IK Rating	IK05	IK05	IK05
Operational Temperature (°C)	-5 to +40	-5 to +40	-5 to +40		Operational Temperature (°C)	-5 to +40	-5 to +40	-5 to +40
Tail Clamp Capacity (mm ²)	25	25	25		Tail Clamp Capacity (mm ²)	25	25	25
Tail Clamp Torque (Nm)	1.5	1.5	1.5		Tail Clamp Torque (Nm)	1.5	1.5	1.5
CPC & N Bars Capacity (mm ²)	16	16	16		CPC & N Bars Capacity (mm ²)	16	16	16
CPC & N Bars Torque (Nm)	2	2	2		CPC & N Bars Torque (Nm)	2	2	2
Switch-Disconnecter Fitted	1 x 100A (CU2MS100)	1 x 100A (CU2MS100)	1 x 100A (CU2MS100)		Switch-Disconnecter Fitted	1 x 100A (CU2MS100)	1 x 100A (CU2MS100)	1 x 100A (CU2MS100)
RCD Fitted	-	2 x 80A 30mA RCD (CU2RCD80A)	2 x 80A 30mA RCD (CU2RCD80A)		RCD Fitted	2 x 80A 30mA RCD (CU2RCD80A)	-	2 x 80A 30mA RCD (CU2RCD80A)
SPD Fitted	-	-	1 x 40kA SPD (CU2SPD275)		SPD Fitted	-	1 x 40kA SPD (CU2SPD275)	1 x 40kA SPD (CU2SPD275)
Free Ways	20	16 (8+8)	14 (7+7)		Free Ways	16	18	14
Nett Weight	5.4kg	6.2kg	6.4kg		Nett Weight	6.2kg	6.4Kg	6.46Kg

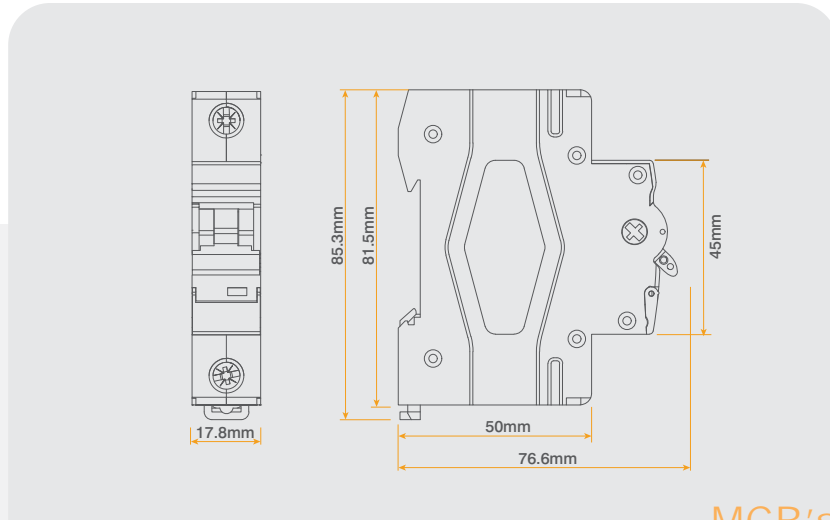

MCB's

	B Curve	C Curve
Rated Operational Voltage (Ue)	230/400 50/60Hz	230/400 50/60Hz
Maximum Rated Current (In)	6A to 63A	6A to 63A
Thermal Operating Limit	(1.13-1.45) x In	(1.13-1.45) x In
Rated Breaking Capacity (Ics)	True 6kA	True 6kA
Number Of Poles	1	1
Insulation Voltage (Ui)	500V	500V
Impulse Withstand Voltage (Uimp)	4000V	4000V
Endurance Operations	Mechanical: 20000 Electrical: 8000	Mechanical: 20000 Electrical: 8000
Trip Type	Thermal/Magnetic Release	Thermal/Magnetic Release
Magnetic Operating Characteristics	(3-5) x In	(5-10) x In
Device Terminal Type	Screwed Lug & Pin	Screwed Lug & Pin
Terminal Capacity	6-25A - 16mm ² Flexible or 25mm ² Rigid 32-63A - 25mm ² Flexible or 35mm ² Rigid	6-25A - 16mm ² Flexible or 25mm ² Rigid 32-63A - 25mm ² Flexible or 35mm ² Rigid
Maximum Torque	2.0Nm	2.0Nm
Operational Temperature (°C)	-5 to +40	-5 to +40



Breaking Curves

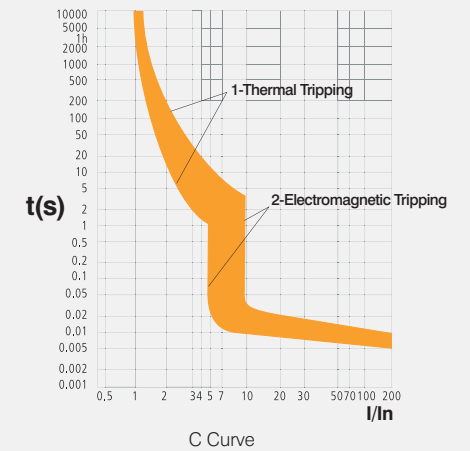
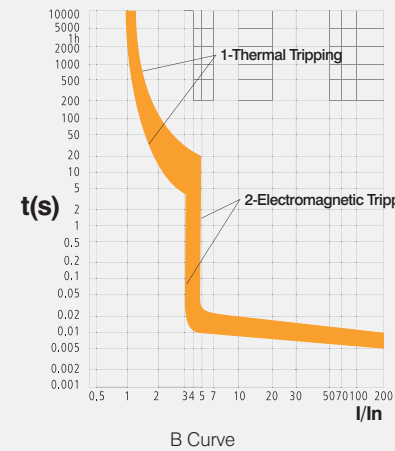

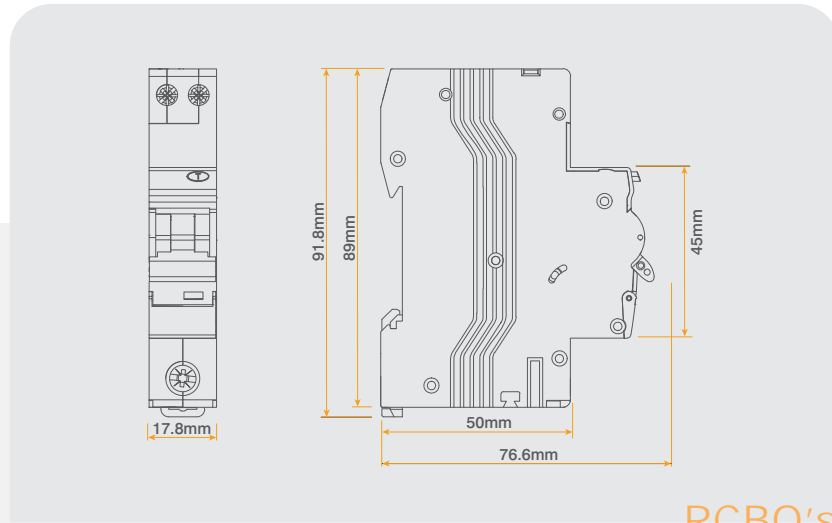

RCBO's

	B Curve & C Curve
Rated Operational Voltage (Ue)	240 50/60Hz
Maximum Rated Current (In)	6A to 40A
Number Of Poles	1P + N
Neutral Tail Length	450
Circuit Protection	Earth fault, overcurrent & short-circuit
Device Terminal Type	Screwed Lug & Pin
Input Terminal Capacity	25mm ² Flexible / 32mm ² Rigid
Output Terminal Capacity	16mm ² Flexible / 25mm ² Rigid
Maximum Torque	Input: 2.0Nm Output: 1.2Nm
RCD Type	A
Residual Current Making & Breaking Capacity (Im)	500A
Tripping Current	30mA
Residual Non-operating Current (IΔn)	0.5
Impulse Withstand Voltage (Uimp)	4000V
Trip Type	Ground Fault: Electronic/Electromagnetic Over Current: Thermal/Magnetic
Endurance Operations	Mechanical: 20000 Electrical: 5000
Operational Temperature (°C)	-25 to +40



Breaking Curves

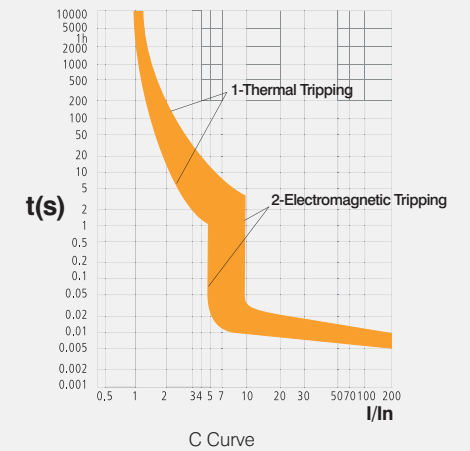
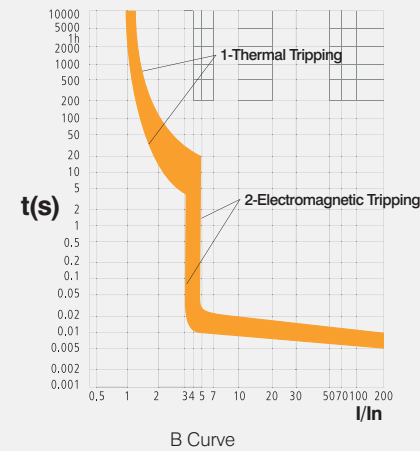

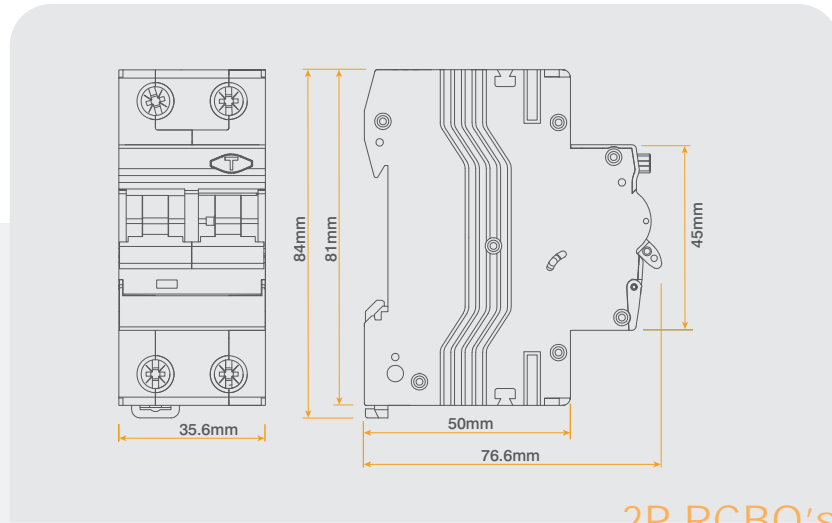

	B Curve & C Curve
Rated Operational Voltage (Ue)	230/50/60Hz
Maximum Rated Current (In)	45A to 63A
Number Of Poles	2
Circuit Protection	Earth fault, overcurrent & short-circuit
Device Terminal Type	Screwed Lug & Pin
Input Terminal Capacity	10mm ² Flexible / 16mm ² Rigid 63A: 16mm ² Flexible / 25mm ² Rigid
Output Terminal Capacity	10mm ² Flexible / 16mm ² Rigid 63A: 16mm ² Flexible / 25mm ² Rigid
Maximum Torque	Input: 2Nm Output: 2Nm
RCD Type	A
Residual Current Making & Breaking Capacity (Im)	500A
Tripping Current	30mA
Residual Non-operating Current (IΔn)	0.5
Impulse Withstand Voltage (Uimp)	4000V
Trip Type	Ground Fault: Electronic Over Current: Thermal/Magnetic
Endurance Operations	Mechanical: 10000 Electrical: 4000
Operational Temperature (°C)	-25 to +40

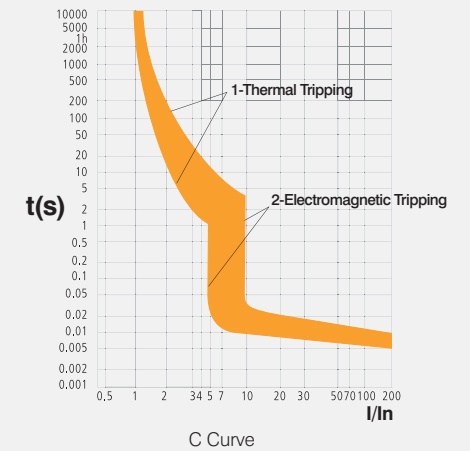
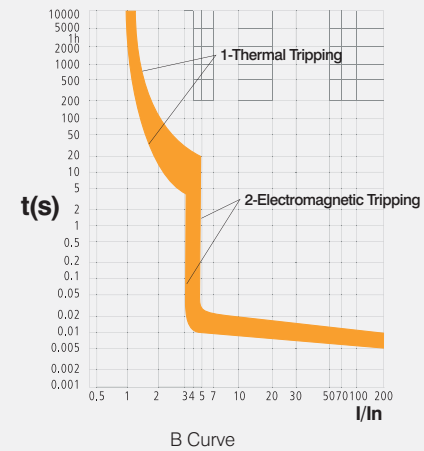

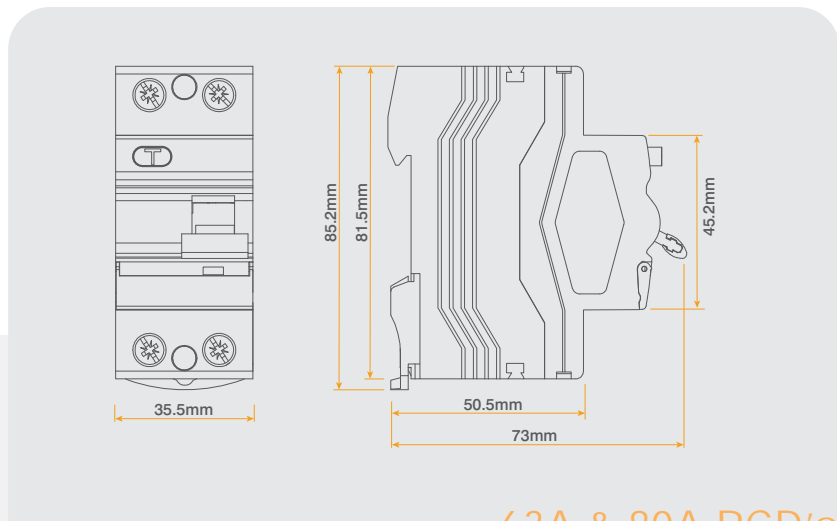

63A & 80A RCD's

	63A 30mA	80A 30mA
Rated Operational Voltage (Ue)	230	230
Maximum Rated Current (In)	63A	80A
RCD Type	A	A
Number Of Poles	2 (1+N)	2 (1+N)
Residual Current Making & Breaking Capacity (Im)	630A	800A
Tripping Current	30mA	30mA
Residual Non-operating Current (IΔn)	0.5	0.5
Impulse Withstand Voltage (Uimp)	4000V	4000V
Endurance Operations	2000 'ON' & 1000 'OFF' Cycles	2000 'ON' & 1000 'OFF' Cycles
Trip Type	Electro-Magnetic Release	Electro-Magnetic Release
Device Terminal Type	Screwed Lug & Pin	Screwed Lug & Pin
Terminal Capacity	16mm ²	25mm ²
Maximum Torque	2.5Nm	2.5Nm
Operational Temperature (°C)	-25 to +40	-25 to +40

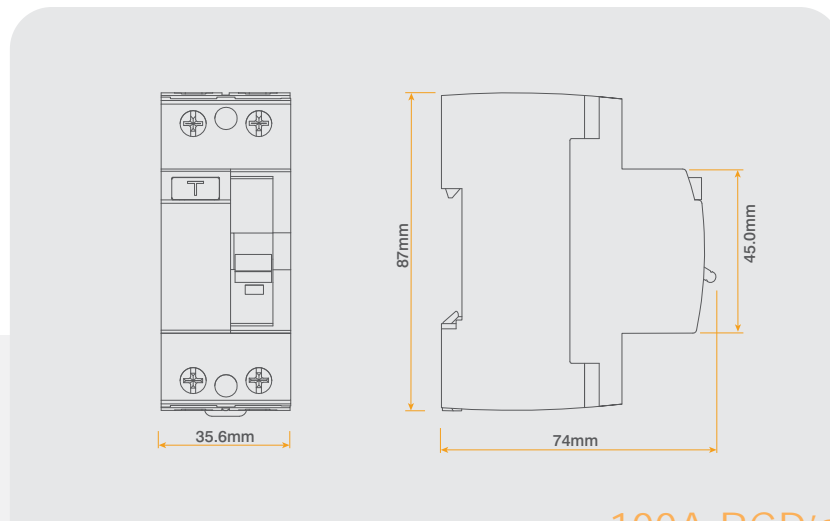

100A RCD's

	100A 30mA
Rated Operational Voltage (Ue)	230
Maximum Rated Current (In)	100A
RCD Type	A
Number Of Poles	2 (1+N)
Residual Current Making & Breaking Capacity (Im)	1000A
Tripping Current	30mA
Residual Non-operating Current (IΔn)	0.5
Impulse Withstand Voltage (Uimp)	4000V
Endurance Operations	2000 'ON' & 1000 'OFF' Cycles
Trip Type	Electro-Magnetic Release
Device Terminal Type	Screwed Lug & Pin
Terminal Capacity	35mm ²
Maximum Torque	2.5Nm
Operational Temperature (°C)	-25 to +40

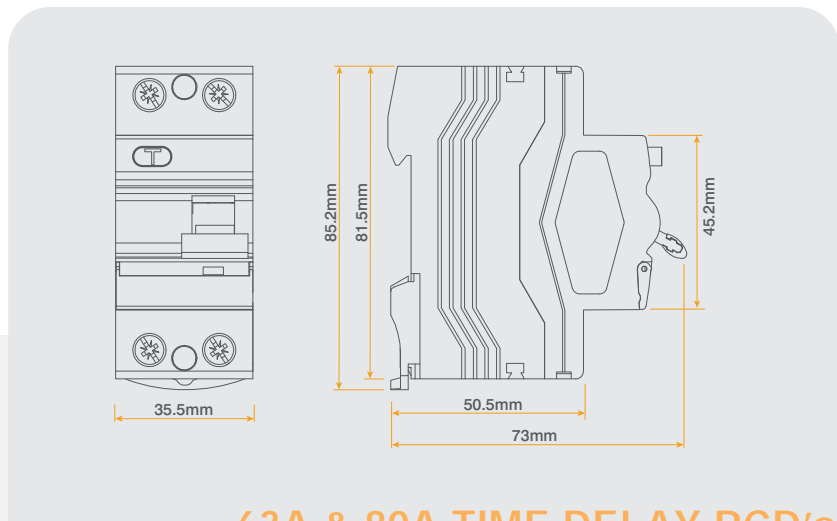

63A & 80A TIME DELAY RCD'S

	63A 30mA	80A 30mA
Rated Operational Voltage (Ue)	230	230
Maximum Rated Current (In)	63A	80A
RCD Type	S	S
Number Of Poles	2 (1+N)	2 (1+N)
Residual Current Making & Breaking Capacity (Im)	630A	800A
Tripping Current	100ma	100ma
Residual Non-operating Current (IΔn)	0.5	0.5
Impulse Withstand Voltage (Uimp)	4000V	4000V
Endurance Operations	2000 'ON' & 1000 'OFF' Cycles	2000 'ON' & 1000 'OFF' Cycles
Trip Type	Electro-Magnetic Release	Electro-Magnetic Release
Device Terminal Type	Screwed Lug & Pin	Screwed Lug & Pin
Terminal Capacity	16mm ²	25mm ²
Maximum Torque	2.5Nm	2.5Nm
Operational Temperature (°C)	-25 to +40	-25 to +40



100A TIME DELAY RCD'S

	100A 30mA
Rated Operational Voltage (Ue)	230
Maximum Rated Current (In)	100A
RCD Type	S
Number Of Poles	2 (1+N)
Residual Current Making & Breaking Capacity (Im)	1000A
Tripping Current	100ma
Residual Non-operating Current (IΔn)	0.5
Impulse Withstand Voltage (Uimp)	4000V
Endurance Operations	2000 'ON' & 1000 'OFF' Cycles
Trip Type	Electro-Magnetic Release
Device Terminal Type	Screwed Lug & Pin
Terminal Capacity	35mm ²
Maximum Torque	2.5Nm
Operational Temperature (°C)	-25 to +40

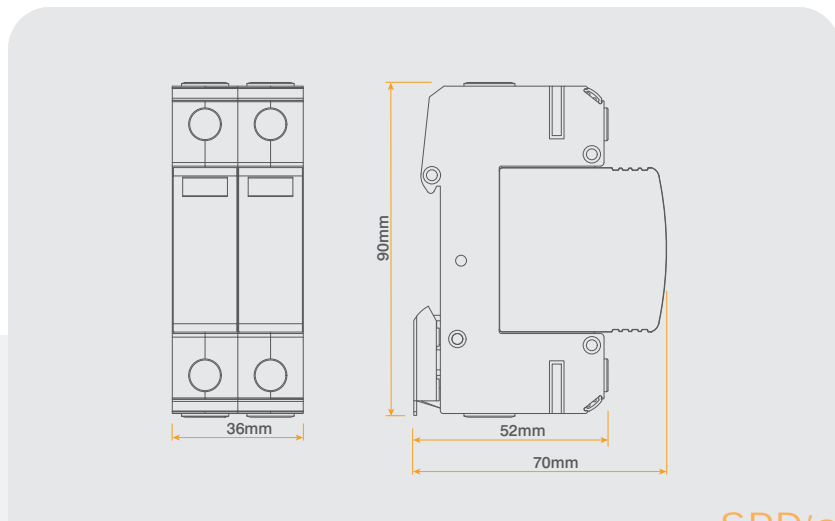

SPD's

Maximum Continuous Operating Voltage (Uc)	275V~
SPD Type	Type 2
Number Of Poles	2
Visual Status (Green)	Normal Function
Visual Status (Red)	Cartridge Replaceable For L&N (Product Ref.CU2SPDC275)
Device Terminal Type	Screwed Lug & Pin
Terminal Capacity	L&N: 2.5mm ² -35mm ² , PE: 4mm ² -35mm ²
Maximum Torque	2.0Nm
Tails Included	Yes
Internal Overcurrent Protection	300A
Maximum Voltage Protection Level (Up)	<1.6Kv
Nominal Discharge Current (In)	20kA (L-N & N-PE)
Maximum Discharge Current (Imax)	40kA (L-N & N-PE)
Response Time (tA)	<25ns
Compatible Earthing Systems	TT / TN
Operational Temperature (°C)	-40 to +70



Protection Devices

Visual Status Indicator

Individual cartridge indication: Green: OK; Red: Replace cartridge (Product Ref: CU2SPDC275 suitable for both L&N).



Green Indicator Light

SPD cartridge is operating correctly.

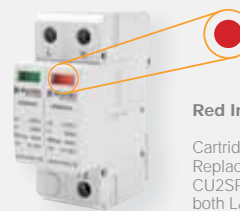

Red Indicator Light

Cartridge is at end of life. Replace cartridge (Product Ref: CU2SPDC275 suitable for both L&N)

Surge Protection

The Type 2, 2 Pole 40kA Surge Protection Device 275Uc (V~) protect all aspects of the installation from an electrical surge, anything from lightning to lightning.

As well as preventing premature aging, destruction of equipment and unnecessary downtime SPDs are recommended to protect sensitive electronic equipment connected to the installation such as computers, televisions, washing machines & LED Lighting.

Technical Data

- Complies with BS EN 61643-1-11
- Internal overcurrent protection 300A
- L, N & E terminal capacity 35mm² maximum.
- Compatible earthing systems TT & TN

Installation and Connection

- The main protection SPDs are installed directly after the main incoming switch or RCCB.
- Connected in parallel to the equipment to be protected.
- Protection is assured in both common and differential modes.
- Additional overcurrent protection is not required.
- The cartridges are to be removed for insulation resistance testing.

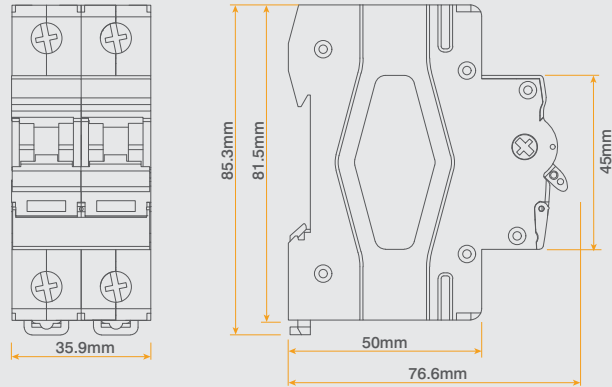

Mains Switch-Disconnecter

Rated Operational Voltage (Ue)	230/415
Maximum Rated Current (In)	100A
Number Of Poles	2
Endurance Operations	Mechanical: 10000 Electrical: 1500
Device Terminal Type	Screwed Lug & Pin
Terminal Capacity	35mm ²
Maximum Torque	2.5Nm
Utilisation Category	AC-22A
Short Circuit Withstand Current (Icw)	12 Ie, t=1s
Short Circuit Making Capacity (Icm)	20 Ie
Making & Breaking Capacity	3Ie, 1.05Ue, COSφ = 0.65
Insulation Voltage (Ui)	690V
Impulse Withstand Voltage (Uimp)	6000V
Operational Temperature (°C)	-25 to +40

Installation Information

All the installation information you need, from fixing centre's, knockout sizes and torque settings.



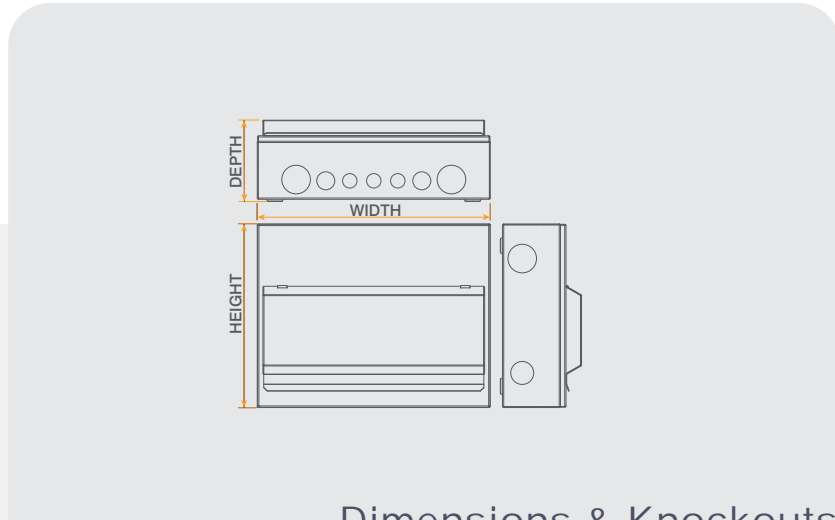

Dimensions & Knockouts

Dimensions (mm)					
Unit Ways	Width	Height	Depth (Body)	Depth (Overall)	XY Fixing Centres
5	168	260	92	116	118 x 199
8	222	260	92	116	172 x 199
10	258	260	92	116	208 x 199
12	294	260	92	116	244 x 199
14	330	260	92	116	280 x 199
16	366	260	92	116	316 x 199
18	402	260	92	116	352 x 199
22	474	260	92	116	424 x 199

Knockouts (mm)				
Unit Ways	Sides (Ø)	Top (Ø)	Bottom (Ø)	Rear
5	1x25, 1x32	2x20, 1x40	2x20, 1x40	60x60
8	1x25, 1x40	2x20, 1x40	2x20, 1x40	100x60
10	1x25, 1x40	4x20, 1x32, 1x40	4x20, 1x32, 1x40	100x60
12	2x40	4x2, 2x40	3x20, 2x25, 2x32	2x100x60
14	1x32, 1x40	2x20, 1x40	2x20, 1x40	2x100x60
16	2x40	4x20, 2x25, 2x40	5x20, 2x25, 2x32	2x100x60
18	1x32, 1x40	2x20, 1x40	2x20, 1x40	2x100x60
22	1x32, 1x40	2x20, 1x40	2x20, 1x40	3x100x60



After fitting all outgoing devices and connecting all outgoing cables, ensure that all connections are tightened to the torque settings stated in the table below, including factory made connections which may have become loose during transit.

Torque Settings

Device Type	Number Of Ways	Maximum Conductor Size	Maximum Torque	
			Input	Output
Main Switch	2	35mm ²	2.5Nm	2.5Nm
RCD	2	16mm ² (63A), 25mm ² (80A), 35mm ² (100A)	2.5Nm	2.5Nm
SPD	2	L&N: 2.5mm ² -35mm ² , PE: 4mm ² -35mm ²	2.0Nm	2.0Nm
MCB	1	16mm ² Flexible or 25mm ² Rigid (Up to 25A)	2.0Nm	2.0Nm
		25mm ² Flexible or 35mm ² Rigid (32A - 63A)		
1P + N RCBO's	1	25mm ² Flexible / 32mm ² Rigid (Input)	2.0Nm	1.2Nm
		16mm ² Flexible / 25mm ² Rigid (Output)		
2P RCBO	2	45A & 50A: 10mm ² Flexible / 16mm ² Rigid (Input & Output)	2Nm	2Nm
		63A: 16mm ² Flexible / 25mm ² Rigid (Input & Output)		
Earth & Neutral Bars		16mm ²	2.0Nm	
Mains Tail Clamp		25mm ²	1.2Nm	



80A and 100A variants are supplied with a 80A Bussmann fuse as standard.

However the following fuses will fit:

Fused Main Switch

Fuse Manufacturer				
Rating	Bussmann	Lawson	MEM	GE
40A	40KR85	ME40	404R	RHF40
45A	45KR85	ME45	454R	-
50A	50KR85	ME50	504R	RHF50
60A	60KR85	ME60	604R	RHF60
70A	70KR85	ME70	-	-
80A	80KR85	ME80	804R	RHF80
100A	100KR85	ME100	-	-